

Gate Valve

Flanged x Flanged

Fabricated – Double Acting

- Flexible action of Stainless Steel Beveled Discs insures a tighter valve over longer periods of time.
- No elastomers to deteriorate.
- Fabricated for greater strength, lighter weight and lower cost, in steel, stainless and aluminum.
- Double acting hand stem threads double the speed of operation. Valve closes in half the time.

MAWP 50 PSI

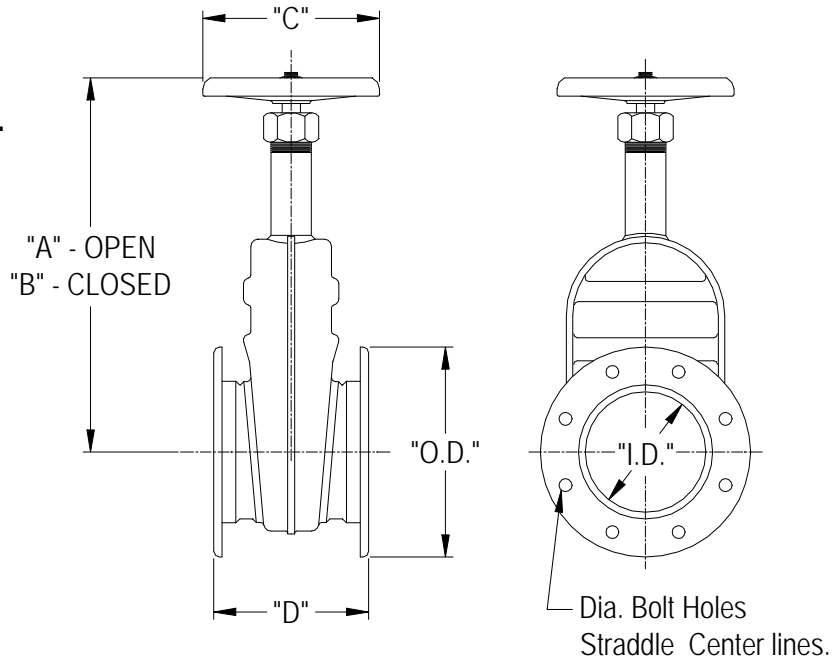

See section 18 Page 4A for parts list.

Flanges are Drilled to TTMA Recommendations.

Dimensions										
Pipe Size	Body				Pipe Thread	Flange				
	A	B	C	D		I.D.	O.D.	B.C.	No.	Dia.
3	14 1/4	12 5/8	4 1/2	4 1/2	N/A	3 1/16	Stl & SS 6 1/8	4 7/8	8	7/16
							Aluminum 5 5/8			
4	15 1/4	13 1/8	6	5 1/4	N/A	4 1/32	Stl & SS 7 1/8	5 7/8	8	7/16
							Aluminum 6 5/8			